

PROLINE

professional welding supplies

XP8 300A

Air Cooled Mig Welding Torch

Rating: 300A, 8.7kW, Mixed Gas (80/20) @ 80% Duty Cycle, EN60974-7 .030"-.045"/Ø 0.8mm to 1.2mm wires

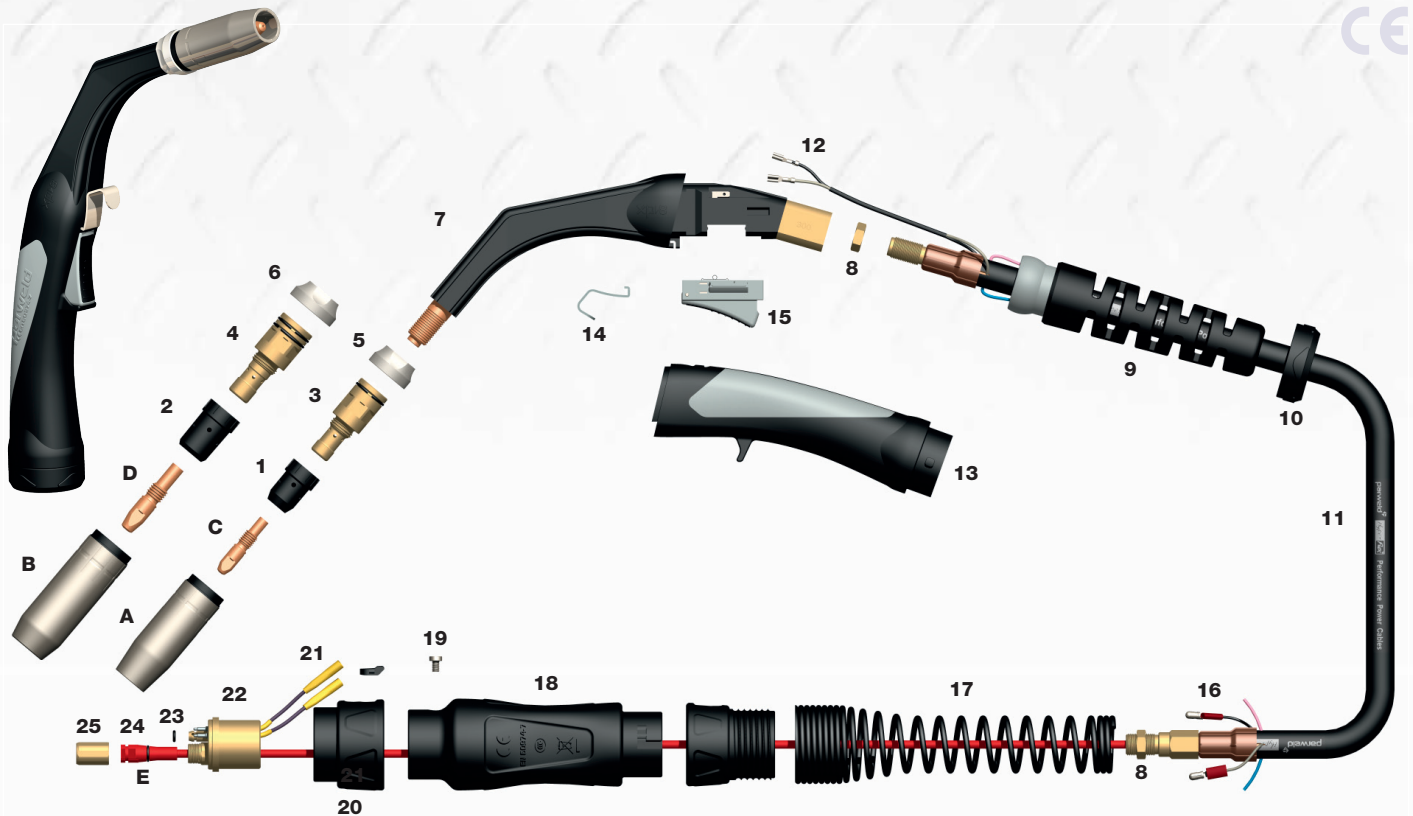

Selecting the correct XP8 Torch

Amperages and duty cycles alone are arbitrary measures of a torches capability.

For a more accurate appreciation wire type, gas type, flow rate and open circuit voltage must all be taken into consideration.

The XP8 is rated in Amps as a guideline but the Kilowattage requirement of a given application provides a far more accurate method for calculating torch selection.

Kilowattage represents the total power rating required and is calculated as follows:

$$\frac{\text{Welding Amps} \times \text{Welding Volts}}{1000} = \text{kW}$$

(Amps x Volts = Watts , 1000 Watts = 1 kW)

Table to show the affect on XP8 performance when using alternate gas types

Model	Mixed Gas (80/20)		Mixed Gas (95/5)		100% CO ₂	
	Amps	kW	Amps	kW	Amps	kW
XP8-300A	300	8.7	280	8.4	375	11.7

Note: All ratings are based on a nominal gas flow of 18lpm. A lower gas flow will result in an increase in working temperature but it will not have any adverse affect as long as the gas flow is within the accepted limits for the welding amperage.

Model				
Stock Code	3M	4M	5M	Model Description
XP300A	-30E	-40E	-50E	Welding Torch c/w Euro Fitting

Nozzles	
Stock Code	Description
A XP2002-10	Tapered Nozzle 3/8"/10mm
XP2002-13	Tapered Nozzle 1/2"/13mm
XP2002-16*	Conical Nozzle 5/8"/16mm
XP2002-16L	Conical Nozzle 5/8"/16mm-Extended
XP2002-19	Cylindrical Nozzle 3/4"/19mm
XP2002-19L	Cylindrical Nozzle 3/4"/19mm-Extended
B XP3002-13	Tapered Nozzle 1/2"/13mm
XP3002-16	Conical Nozzle 5/8"/16mm
XP3002-16L	Conical Nozzle 5/8"/16mm-Extended
XP3002-19	Cylindrical Nozzle 3/4"/19mm
XP3002-19L	Cylindrical Nozzle 3/4"/19mm-Extended

Contact Tips	
Stock Code	Description
C XP2003-08	Contact Tip .030"/0.8mm M8 CuCrZr
XP2003-09	Contact Tip .035"/0.9mm M8 CuCrZr
XP2003-10	Contact Tip .040"/1.0mm M8 CuCrZr
XP2003-10A	Contact Tip .040"/1.0mm Aluminium M8 CuCrZr
XP2003-12*	Contact Tip .045"/1.2mm M8 CuCrZr
XP2003-12A	Contact Tip .045"/1.2mm Aluminium M8 CuCrZr
XP2003-13	Contact Tip .052"/1.3mm M8 CuCrZr
D XP3003-08	Contact Tip .030"/0.8mm M10 CuCrZr
XP3003-09	Contact Tip .035"/0.9mm M10 CuCrZr
XP3003-10	Contact Tip .040"/1.0mm M10 CuCrZr
XP3003-10A	Contact Tip .040"/1.0mm Aluminium M10 CuCrZr
XP3003-12	Contact Tip .045"/1.2mm M10 CuCrZr
XP3003-12A	Contact Tip .045"/1.2mm Aluminium M10 CuCrZr
XP3003-13	Contact Tip .052"/1.3mm M10 CuCrZr

Liners	
Stock Code	Description
E XP2024-09-30	Steel Liner .023"-.035"/0.6mm/0.9mm x 10ft/3m
XP2024-09-40	Steel Liner .023"-.035"/0.6mm/0.9mm x 13ft/4m
XP2024-09-50	Steel Liner .023"-.035"/0.6mm/0.9mm x 16ft/5mt
XP2024-12-30*	Steel Liner .040"-.045"/1.0mm/1.2mm x 10ft/3m
XP2024-12-40*	Steel Liner .040"-.045"/1.0mm/1.2mm x 13ft/4mt
XP2024-12-50*	Steel Liner .040"-.045"/1.0mm/1.2mm x 16ft/5m
NI XP2024PC-12-30	Polyamide-Copper Liner .030"-.045"/0.8mm-1.2mm x 10ft/3mt
XP2024PC-12-40	Polyamide-Copper Liner .030"-.045"/0.8mm-1.2mm x 13ft/4m
XP2024PC-12-50	Polyamide-Copper Liner .030"-.045"/0.8mm-1.2mm x 16ft/5mt
XP2024PS-12-30	Polyamide-Steel Liner .030"-.045"/0.8mm-1.2mm x 10ft/3m
XP2024PS-12-40	Polyamide-Steel Liner .030"-.045"/0.8mm-1.2mm x 13ft/4m
XP2024PS-12-50	Polyamide-Steel Liner .030"-.045"/0.8mm-1.2mm x 16ft/5m

Note: For flux core wire 1.6mm liner is recommended – Stock Code: XP2024-16-30

Components		
Stock Code	Description	* Denotes Standard Build
1 XP2004B*	Diffuser-Plastic – M8 Head	
NI XP2004C	Diffuser-Ceramic – M8 Head	
2 XP3004B	Diffuser-Moulded c/w Ceramic Insert – M10 Head	
NI XP3004C	Diffuser-Ceramic – M10 Head	
3 XP2005*	Head Assembly – M8 Tips	
4 XP3005	Head Assembly – M10 Tips	
5 XP2006A*	Aluminium Heat Shield – M8 Head	
NI XP2006B	Heat Shield Moulded – M8 Head	
6 XP3006A	Aluminium Heat Shield – M10 Head	
NI XP3006B	Heat Shield Moulded – M10 Head	
7 XP3001	Swan Neck	
8 XP2016	Lock Nut M12	
9 XP3008	Ball Joint and Cable Support	
10 XP2009	Handle Lock Nut	
11 XP3010-30	Cable Assembly x 3m/10ft	
XP3010-40	Cable Assembly x 4m/13ft	
XP3010-50	Cable Assembly x 5m/16ft	
12 XP2011	Cable Terminal Female	
13 XP2012	Handle Kit c/w Lock Nut	
14 XP2013	Hanger Hook	
15 XP2014	Trigger	
16 XP2015	Cable Terminal Male	
17 XP3017	Cable Support	
18 XP2018	Air Cooled Gun Plug Housing c/w Nut	
19 XP2019	Gun Plug Screw	
20 XP2020	Gun Plug Nut	
21 Spring Pin 2	Spring Pin Assembly	
22 XP2022	Gun Plug Body c/w Spring Pins	
23 XP2023	Gun Plug Body O Ring	
24 XP2025	Liner Nipple O Ring	
25 XP2026	Liner Retaining Nut	

Parweld XP8 Torches enable you to repair the Neck End of the Power Cable, please order Stock Code XP3042: 300A Power Cable Repair Kit