



SV3000

AUTO-DARKENING WELDING HELMET



INSTRUCTIONS FOR USE

SOLAR POWER AUTO-DARKENING HELMET TYPE



WARNING

Read and understand all instructions before use!

The STRATA SV3000 helmet is designed to protect the eyes and face from sparks, spatter, and harmful radiation under normal welding conditions. They will not protect against severe impact hazards, including fragmenting grinding disks.

This helmet will never protect against explosive devices or corrosive liquids. Machine guards or eye splash protection must be used when these hazards are present.

Impact resistant, primary eye protection, spectacles or goggles that meet appropriate protection specifications, must be worn at all times when using this welding helmet.

Avoid work positions that could expose unprotected areas of the body to spark, spatter, direct and/or reflected radiations. Use adequate protection if exposure can not be avoided.

BEFORE WELDING

Check the front cover lens to make sure that they are clean, and that no dirt is covering the sensors on the front of filter cartridge . Also check the front / inside cover lens and the front lens retaining frame to make sure that they are secure.

Inspect all operating parts before each use for signs of wear or damage. Any scratched, cracked, or pitted parts should be replaced immediately before using again to avoid severe personal injury.

Check for light tightness before each use.

Select the shade number you require at the turn of a shade knob (len specific).Finally be sure that the shade number is the correct setting for your application.

Adjust headband so that the helmet is seated as low as possible on the head and close to your face. Adjust helmet's angle when in the lowered position by turning the adjustable angle limitation washer.

Do not make any modifications to either the welding lens or helmet, other than those specified in this manual. Do not use any replacement parts other than those specified in this manual. Unauthorized modifications and replacement parts will void the warranty and expose the user to the risk of personal injury.

Failure to follow these warnings and/or failure to follow all of the operating instructions could result in severe personal injury.

PARTS LIST & ASSEMBLY

SV3000 (ADF model WH801)

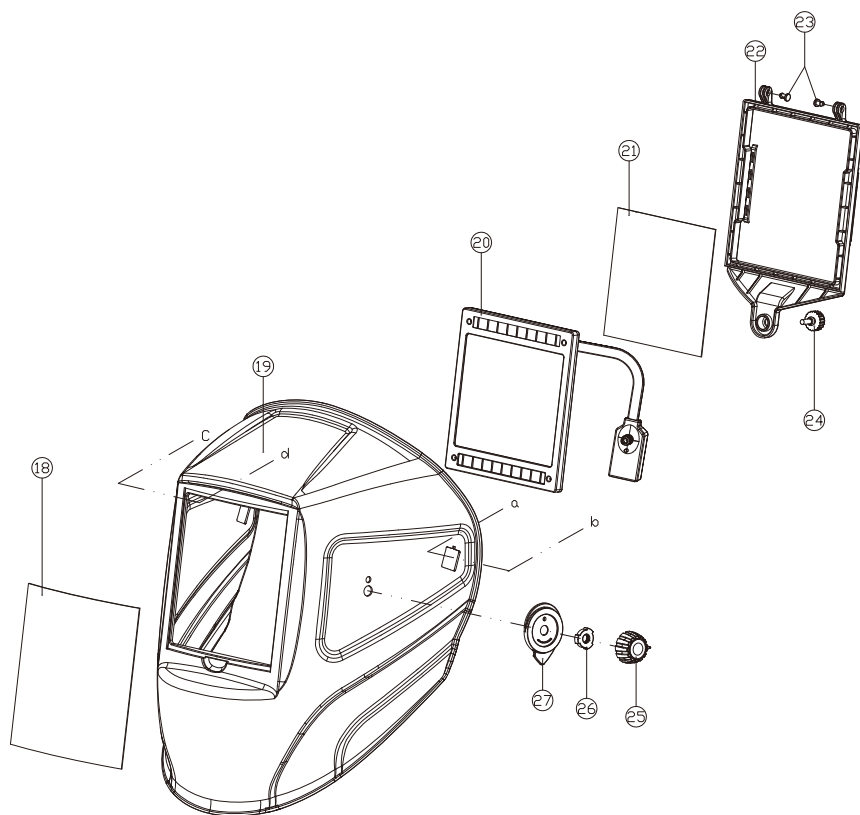

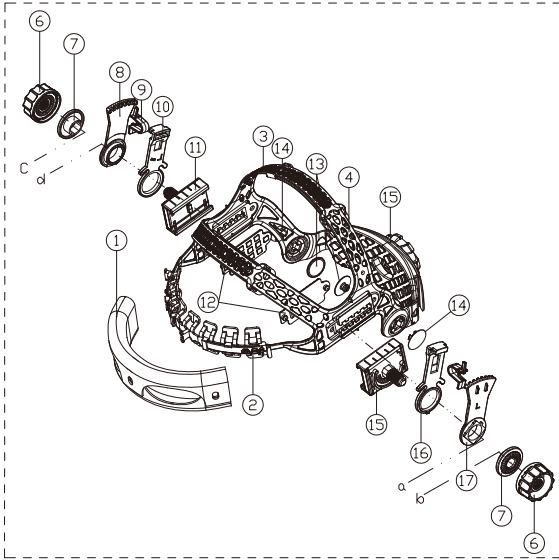

Part list

ITEM	DESCRIPTION	QTY
1	Sweatband	1
2	Forehead band	1
3	Right belt	1
4	Left belt	1
5	Occipital pad	1
6	Headband adjusting nut	2
7	Washer	2
8	Right Limitation Washer	1
9	Angle pin	2
10	Right Adjustable Washer	1
11	Right slider	1
12	Side trim	2
13	Rotating shaft inside trim	2
14	Rotating shaft outside trim	2
15	Left slider	1
16	Left Adjustable Washer	1
17	Left Limitation Washer	1
18	Front protection plate	1
19	Helmet shell	1
20	Auto-darkening lens assembly	1
21	Rear protection plate	1
22	Press frame	1
23	Obturator Spindle	2
24	Nuts	1
25	Shade Adjustment knob	1
26	Fastener	1
27	Shade indicator	1

I. Product Features

- This product is of completely new design, with shell material high-and-low-temperature resistant, corrosion resistant, flame retardant, soft, light tight, intensity high, and durable.
- Clear vision on the work piece both prior and during welding, which means improved quality and higher efficiency.
- Overall-process protection against ultraviolet (UV) and infrared (IR) radiation. SV3000 is equipped with lithium battery and solar cells that extends the life of the battery.
- The product is in full conformity with related ANSI, CE, CSA, AS/NZS safety standards.

II. Operating Instruction

1. Peel off the protective film inside and outside the surfaces of lens.
2. The filter screen is transparent enabling clear vision of what you are welding.
Once you start welding the filter screen automatically changes from clear to dark. It will then return to clear when you have stopped welding.
3. Adjust the operation mode to Welding or Grinding.(Len specific). While operating in Grinding mode, the filter does not react to welding arc and will keep clear.
4. Adjust the Shade(Lens specific) number knob according to different welding current and welding process to select proper shade number: see attached table 1;
5. Adjust the sensitivity level (Lens specific) Stop welding, adjust the sensitivity level to high until the filter flashes. Adjust the sensitivity level a little lower once this happens.
6. Adjust the delay time (Lens specific) The delay time feature is the amount of time it takes for the welding lens to return to a clear state after the welding process has finished.
7. Adjust the headgear: see attached figure 2.
 - a. Place the helmet on. Press the adjustable knob down (at the rear head position). At the same time rotate the knob counterclockwise to increase the circumference of the headband, or rotate the knob clockwise to decrease the circumference. See Figure 2.a.
 - b. Adjust the depth of the helmet to best position. See figure 2.b
 - c. Adjust the distance between the helmet and your face. See figure 2.c
 - d. Adjust the Angle limitation position of the helmet. See figure 2.d

Figure 2

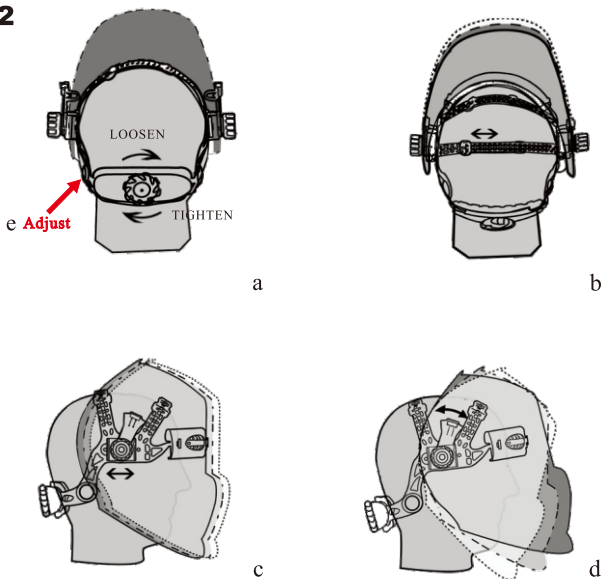

e. Adjust the Angle behind you head to suit your headform

By Adjusting as per the above, the welding helmet will be more comfortable and will enable you to work more skilfully.

III.Warning

- SV3000 applies to all kinds of welding operations.
- The Autodarkening filter must be equipped with outside protection plate to prevent potential unrepairable hazard.
- Change the scratched or broken lens frame that reduces visual field and protection as soon as possible.
- Change the scratched or broken protection plate, do not bump into lens during replacement.
- Before welding, select proper shade number according to welding process.
- The operating temperature range is 23 F to 131 F (-5°C to 55°C). When ambient temperature is below the lower limit, the response speed of liquid crystal materials of lens frame assembly slower a little, no other protections will be affected.

Headgear instruction

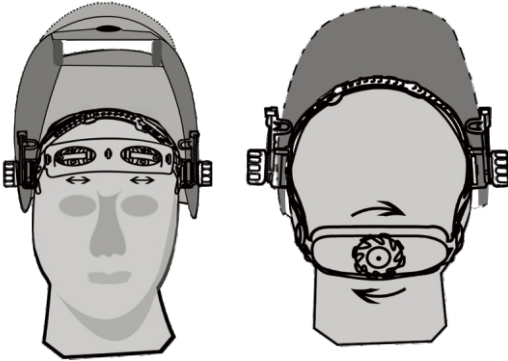

Handband adjustment

The helmet should be adjusted to cover the eyes and face effectively while welding. The size of the headband and the position of the forehead band can be manually adjusted to fit securely. Rotary gear and adjust the tightness until it feels comfortable. The top head band should be adjusted to tightly to the forehead and back of your head.

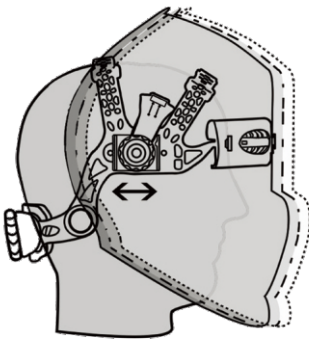

Distance

The distance from the lens can be adjusted by press angle pin then dolly move sliders. There are 5 position possible."

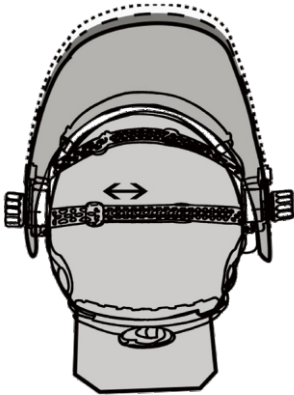

Headgear depth

The depth of the headgear can be adjusted to sit above your brow. Tighten/loosen the two slotted straps to fit the top of your head."

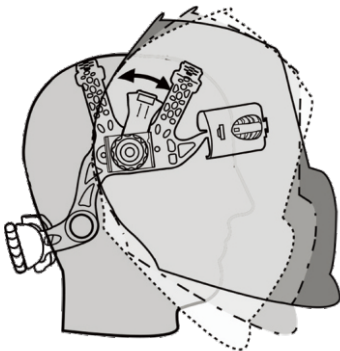

Incline

The ideal helmet position is when your eyes are at 90° angle behind the lens. There are 7 incline angles possible. Press side adjustable washer and move the headgear to the required angle. "

- Do not store lens frame in a location near a heat source or in a high moisture place.
- Do not clean lens frame with alcohol, gasoline, or diluted solvent; and do not immerse it into water.
- Frequently change the sweatband.
- Change failure parts with the parts provided by the authorized supplier.
- Should this helmet not darken upon striking an arc, stop welding immediately and contact your supervisor or your dealer.

IV. TECHNICAL SPECIFICATIONS

MODEL	WH800 Series			WH600 Series		
	WH801	WH804	WH806	WH602	WH603	WH604
Cartridge Size (mm)	133*114			133*114		
Viewing Window Size (mm)	100*93			100*67		
Lens Thickness (mm)	9			9		
Weight (g)	170	197	197	160	150	179
Light State	DIN4			DIN4		
Dark State	DIN5-8/ DIN9-13			DIN5-9/DIN9-13		
Switching time (ms)	0.04			0.04		
Delay time Adjustment	Inside & Stepless (0.15-0.80s)	Outside & Stepless (0.15-0.80s)		Inside & Stepless (0.15-0.80s)		Outside & Stepless (0.15-0.80s)
Sensitivity Adjustment	Inside & Stepless	Outside & Stepless		Inside & Stepless		Outside & Stepless
Shade Adjustment (stepless)	Outside			Outside	Inside	Outside
Sensors	4			4		
Operation temperature	-5℃(23ℱ) ~ +55℃(131ℱ)			-5℃(23ℱ) ~ +55℃(131ℱ)		
Grinding	Outside			Outside	Inside	Outside
Power Supply	Replaceable Li-Mn & Solar Combination			Replaceable Li-Mn & Solar Combination		
TIG Capability	>2A			>2A		
Warranty (years)	2			2		
Optical Class	1/1/1/2			1/1/1/2		
Certification	CE EN379 , ANSI Z87.1			CE EN379 , ANSI Z87.1		
Inner protection lens(mm)	133.7*96.5*1.0			103.7*69.5*1		

Material of helmet: NYLON

Weight: 490g (SV3000) (May differs depending on filter models & painting)

Battery & Disassemble Procedure

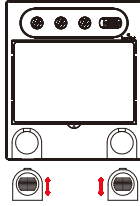

WH9602/WH9603/WH9604

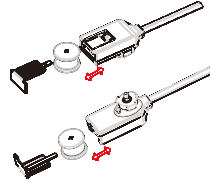

WH9801

Filter, Protection Plate Assemble & Disassemble Procedure

①

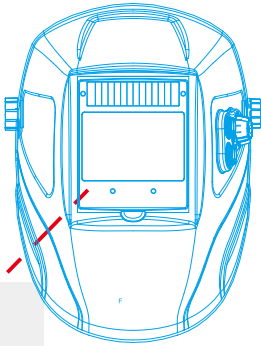

②

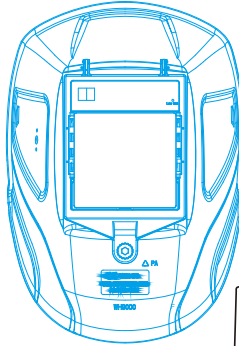

③

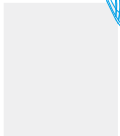
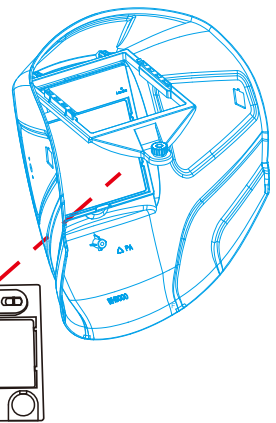

Severe personal injury could occur if the user fails to follow the aforementioned warnings, and / or fails to follow the operating instructions.

COMMON PROBLEMS AND REMEDIES

***Irregular Darkening Dimming**

Headband has been set unevenly and there is an uneven distance from the eyes to the filter's lens(Reset headband to reduce the difference to filter).

****Auto-Darkening Filter Does Not Darken Or Flickers**

Front cover lens is soiled or damaged (change lens cover)

Sensors are soiled (clean the sensors' surface)

Welding current is too low (Adjust sensitivity to high)

*****Slow response**

Operating temperature is too low(do not use at temperatures below-5°C or 23°F).

****** Poor Vision**

Front / Inside cover lens and / or filter lens are soiled(change lens)

There is insufficient ambient light

Shade number is incorrectly set (reset the shade number)

*******Welding Helmet Slips**

Headband is not adjusted properly(readjust headband)

WARNING! Operator must stop using the auto-darkening filter welding helmet immediately if the above-mentioned problems cannot be corrected.Contact the dealer.

NOTE: All specifications and technical data are subject to change without prior notification.

Attached Table 1

Recommended Shade Number According to BS679 and EN169

Welding Process	Arc Current(Amperes)																						
	0.5	1	2.5	5	10	15	20	30	40	60	80	100	125	150	175	200	225	250	275	300	350	400	450
SMAW	9								10	11					12				13			14	
MIG(heavy)	10										11			12				13			14		
MIG(Light)	10										11			12		13		14		15			
TIG,GTAW	9							10	11		12		13		14								
MAG/CO ₂	10										11	12	13				14		15				
SAW	10												11	12	13	14	15						
PAC	11										12				13								
PAW	2.5	3	4	5	6	7	8	9	10	11	12		13		14			15					

Adopt greater or smaller shade number pursuant to the field condition.

Warranty

As part of an on-going commitment to excellence in product support, Euroquip offers a comprehensive product warranty program.

In order to qualify for full warranty support, your product must be registered. Product not registered with Euroquip is supported by a base 12 month warranty only. Spare parts and technical support will not be available for an unregistered product outside of this base warranty period. If a Euroquip dealer has not already registered your product, please register it online or download a physical registration form at www.euroquip.co.nz.

**Registered warranty period for
STRATA SV3000
Warranty 2 years on ADF screen**

Warranty covers failure caused by manufacturing and material defects in the product, during the warranty period specified. The warranty period begins when the product is purchased by the end user. Warranty is not transferrable and is only claimable by the original purchaser.

Warranty does not cover parts that are subject to wear and tear from usage.

Warranty covers failure of a product caused by defective materials and/or manufacturing for the period given and the usage specified by Euroquip. The warranty period begins when the product is purchased by the end user. Warranty is not transferrable and is only claimable by the original purchaser.

Warranty also does not cover failure caused by the untimely replacement or service of the above wearing parts. Evidence must be provided that the product has been maintained and serviced suitably for a claim to be considered under warranty.

Failure caused by incorrect operation of the product, lack of proper care and maintenance of the product, external damage, external circumstances such as contaminated fuel or poor water supply, modifications to the product, attempted repair/ service by a party other than an Approved Service Agent, is not covered under warranty.

Warranty does not cover pre delivery service and adjustment, or failure that may occur as a result of lack of/ incorrect pre delivery service and adjustment.

Warranty does not cover any incidental, indirect or consequential loss, damage or expense that may result from any defect, failure or malfunction of a product.

Should any issue be found to be a combination of a warranty failure and a non-warranty issue, the repair cost component to rectify and repair the non-warranty failure is the customers' full responsibility.

The decision that an issue with a product qualifies as a warranty claim is made at the sole jurisdiction of Euroquip.

No costs incurred will be considered under warranty if repairs are carried out by a party other than a Euroquip Approved Service Agent, unless with prior consent in writing from Euroquip.

It is the responsibility of the purchaser to deliver a product under warranty to the nearest relevant service agent or product reseller. Warranty does not cover call outs, mileage and freight costs.

If a product is repaired under warranty, parts and labour required for the repair will be supplied at no charge. Warranty assessment and repair will be scheduled and executed according to the normal work flow at the service location and depending on the availability of suitable replacement parts.

This warranty policy is an additional benefit and does not affect the legal rights of any end user, reseller or service agent.



Scan here to register your product

<http://www.euroquip.co.nz/Contact+Us/Product+Registration+Form.html>