



# GT2100ESi ELECTRIC START INVERTER GENERATOR

## 2000W



REMOTE  
START



Please ensure that you read this manual in full before using your machine and follow the maintenance and operation instructions carefully.

## OPERATING INSTRUCTIONS

# Contents

<b>Introduction</b> .....	<b>3</b>
<b>Environmental Protection</b> .....	<b>3</b>
<b>Scope of Product</b> .....	<b>3</b>
<b>Description of Symbols</b> .....	<b>3</b>
<b>Specifications</b> .....	<b>3</b>
<b>Operator Safety</b> .....	<b>4</b>
Safety Rules.....	4
<b>Unpacking the Generator</b> .....	<b>8</b>
<b>Box Contents</b> .....	<b>9</b>
<b>Features and Controls</b> .....	<b>9</b>
<b>Operating</b> .....	<b>13</b>
Operating Checklist.....	13
Starting the Generator Set.....	18
Remote Control Use .....	20
Connecting to Electrical Devices.....	21
Loading Capacity.....	22
Stopping the Generator Set.....	23
Parallel Operation.....	23
<b>Maintenance</b> .....	<b>24</b>
Maintenance Schedule.....	25
Remote Control Battery Replacement.....	26
Generating Set Maintenance.....	26
Engine Maintenance.....	27
<b>Troubleshooting</b> .....	<b>31</b>
<b>Storage and Transportation</b> .....	<b>32</b>
<b>Specifications</b> .....	<b>33</b>
Specification Parameter Table.....	33
Wiring Diagram.....	34
<b>Warranty</b> .....	<b>35</b>

## Introduction

Your new GT Power Generator will more than satisfy your expectations. It has been manufactured under stringent quality standards to meet superior performance criteria. You will find your new tool easy and safe to operate, and, with proper care, it will give you many years of dependable service.

Carefully read through this entire Instruction Manual before using your new Generator. Take special care to heed the cautions and warnings.

Your generator has many features that will make your job faster and easier. Safety, performance, and dependability have been given top priority in the development of this tool, making it easy to maintain and operate.

## Environmental Protection

Recycle unwanted materials instead of disposing of them as waste. All tools, hoses and packaging should be sorted, taken to the local recycling centre and disposed of in an environmentally safe way.



## Scope Of Product

This product is suited for home, camping and emergency power applications. It will operate most powertools, appliances and lighting.

## Description Of Symbols

The rating plate on your tool may show symbols. These represent important information about the product or instructions on its use.



Wear hearing protection.  
Wear eye protection.  
Wear breathing protection.



Conforms to relevant standards for electromagnetic compatibility.

## Specifications

AC Output:	230V AC ~ 50Hz
Rated Power:	1700W
Peak Power:	2000W
Phase:	Single
Power Factor:	COS $\emptyset$ = 1
Displacement:	79cc
Engine:	3HP, 4 stroke
No Load Speed:	3000 RPM
Fuel Tank Capacity:	4L
Fuel Type:	Unleaded petrol
Oil Type:	SAE30 4 Stroke
Operation Noise Level:	51dBA / 7m
Net Weight:	19.7kg

## Operator safety

### Safety rules



Pay attention to this safety alert symbol. Obey all safety messages that followed by this symbol to avoid possible property damage. INJURY or DEATH.

Each safety message is preceded by a safety alert symbol and one of three words, DANGER, WARNING, or CAUTION.

#### **⚠ DANGER**

Indicates a hazardous situation which, if not strictly complied with, will result in substantial property damage, serious injury or DEATH.

#### **⚠ WARNING**

Indicates a hazardous situation which, if not strictly complied with, may result in property damage, serious injury or DEATH.

#### **⚠ CAUTION**

Indicates a hazardous situation which, if not strictly complied with, could result in property damage or injury.



#### **⚠ WARNING**

**READ THIS MANUAL COMPLETELY BEFORE OPERATING.**

DO NOT operate this generating set until you have read ALL safety, Operation, and maintenance instructions listed in this manual.

**Failure to follow the instructions may result in property damage, INJURY or DEATH.**

The warnings and precautions discussed in this manual cannot cover all possible conditions and situations that may occur. It must be understood by the operator that common sense and caution are factors which cannot be built into this product, but must be possessed by the operator.

#### **⚠ WARNING**

This generating set is intended for residential consumer use only.

Air cooled generating sets cannot be run full time.

No personal-modified any part of the generating set or any unsuitable usage is allowed.



**⚠ DANGER****TOXIC FUMES**

The exhaust of the engine contains carbon monoxide, an odorless, colorless, poison gas. Using engine indoors **CAN KILL YOU!**

**NEVER** use inside any building or any kind of enclosure, **EVEN IF** doors and windows are open.

Place the engine in a well-ventilated area and carefully consider wind and air currents when positioning the engine.

**⚠ WARNING****ACID**

Be careful when using any battery.

Keep away from flame, heat or spark.

Battery will exhaust hydrogen while charging. Only charge a battery in a well-ventilated place.

Avoid spilled battery acid. If acid liquid contact with skin, wash immediately with clean water.

**⚠ WARNING****FIRE**

Operation of this engine may create sparks that can start fires around dry vegetation.

This engine may not be equipped with a spark arresting muffler. If the engine will be used around flammable materials, or on land covered with materials such as agricultural crops, forest, brush, grass, or other similar items, then an approved spark arrester must be installed.

In some area, a spark arrester is required by law.

Please contact local fire agencies for laws or regulations relating to fire prevention requirements.

**⚠ WARNING****KICKBACK**

Rapid retraction of the starter cord will pull hand and arm towards the engine faster than you can let go.

Unintentional startup can result in accident.

**WARNING****HOT SURFACE**

Running engines produce heat. Severe burns can occur on contact.

DO NOT touch engine while operating or just after stopping. Avoid contact with hot exhaust gases.

Maintain at least three feet of clearance on all sides to ensure adequate cooling.

Combustible material can catch fire on contact.

Maintain at least five feet of clearance from combustible materials.

Always wipe off spilled fuel and wait until the fuel has dried before starting the engine.

DO NOT operate the engine with known leaks in the fuel system.

Use proper fuel storage and handling procedures.

DO NOT store fuel or other flammable materials nearby.

Empty the fuel tank before storing or transporting this engine.

Keep fire extinguisher handy and be prepared if a fire starts.

**DANGER****FIRE OR EXPLOSION**

Gasoline is highly flammable and extremely explosive.

Fire or explosion can cause severe burns or death.

Keep flammable items away while handling gasoline.

Fill fuel tank outdoors and in a well-ventilated area with the engine stopped.

**WARNING**

Before each use, check for loose or damaged parts, signs of oil or fuel leaks, and any other condition that may affect proper operation.

Repair or replace all damaged or defective parts immediately.

Locate all operating controls and safety labels.

Make sure all the safety instructions are in right and

working condition. Operate only on level surfaces.

DO NOT expose generating set to excessive moisture, dust, or dirt.

Keep all safety guards in place and in proper working order at all times.

DO NOT allow any material to block the cooling slots.

DO NOT allow children or untrained persons to operate the generating set.

DO NOT run the generating set unattended. Turn off the generating set before leaving the area.



### **MOVING PARTS**

Moving parts can cause severe injury. Keep hands and feet away .

DO NOT operate engine with covers, shrouds, or guards removed.

DO NOT wear loose-fitting clothing, dangling drawstrings or items that could become caught. Tie up long hair and remove jewelry.

The moving parts may catch operator's hand, feet, hair or clothes that will cause traumatic amputation or broken bones, fracture.

NEVER place fingers, hands, or body near the engine when it is running.



**⚠ DANGER**

### **ELECTRIC SHOCK**

This generating set produces powerful voltage and the electricity **CAN KILL YOU**.

This generating set must be properly connected to an appropriate ground to help prevent electric shock.

Failure to properly ground generating set can result in electrocution, especially if the generating set is equipped with a wheel kit.

Consult an electrician for local grounding requirements.

Installation should be performed by a certified electrician.

Improper Installation can result in electric shock and

death. To reduce the risk of electric shock. DO NOT use electrical cords that are worn, frayed, bare or otherwise damaged.

DO NOT touch bare wires or receptacles.

DO NOT operate generating set in wet weather. Keep the generating set dry.

DO NOT handle generating set or electrical cords while standing in water, while barefoot, or while hands or feet are wet.

Keep children or pets away from the generating set.

DO NOT hook up any generating set to a building's electrical system without the proper use and installation of a transfer switch installed by a qualified electrician.

When using generating set for backup power, notify utility company. Use approved transfer generating set to isolate generating set from electric utility.

Failure to isolate generating set from power utility can result in death or injury to electric utility workers due to backfeed of electrical energy

## Unpacking the Generator

### WARNING

Always have assistance when lifting the generator. The generator is heavy; lifting it could cause bodily harm. Avoid cutting on or near staples to prevent personal injury.

1. Carefully cut packing tape on top of carton.
2. Fold back top flaps to reveal instruction manual on top of the upper packing tray. Remove manual and save it for reference.
3. Remove contents from upper packing tray.
4. Remove and discard upper packing tray.
5. Unfold top of the plastic bag enclosing the generator.
6. Lift generator out of plastic bag and carton.
7. Recycle or dispose of packaging materials properly

## Box Contents

Check the contents against those listed below. If any parts are missing, please contact your local GT Power dealer.

- Generator
- Instruction Manual
- USB Adapter
- Remote Start Controller
- 500ml Oil Bottle
- Spark Plug Socket Wrench
- M8 Spanner

## Features and controls

1. Carry Handle
2. Fuel Tank Cap
3. Ventilation Knob
4. Spark Plug Maintenance Cover
5. Recoil Starter
6. Control Panel
7. Muffler



## Control Panel

1. Run Indicator
2. Overload Indicator
3. Low Oil Indicator
4. Push Button Start
5. Digital Volt Meter
6. Two-in One Switch
7. Parallel Kit Terminal
8. Ground Terminal
9. AC 230V Plug Socket
10. 12V 8.3A Plug Socket
11. 12V Breaker Switch
12. 230V Reset Switch
13. Eco Mode Switch

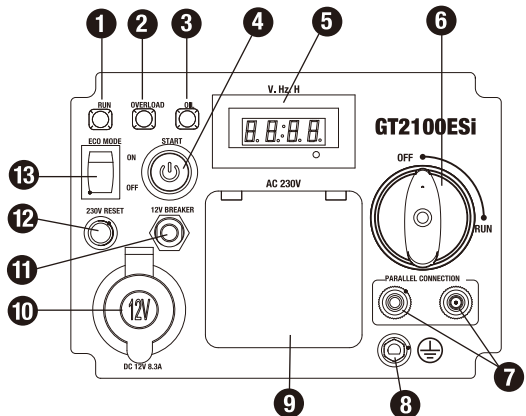

### Running indicator (green)

The running indicator lights up when generating set starts and has normal output power.

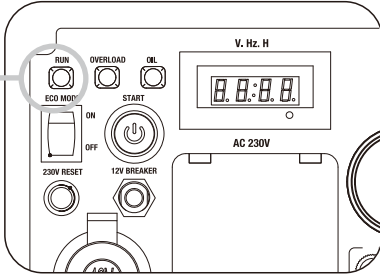

### Overload indicator (red)

When the overload indicator is on, it indicates that the generating set is overloaded and may cause overheating of the frequency, or an increase of AC voltage. The AC protector will stop the output of the generating set to protect the electric equipment and the generating set itself. At this time, the running indicator (green) is off and the overload indicator (red) is on, but the engine is still in running state.

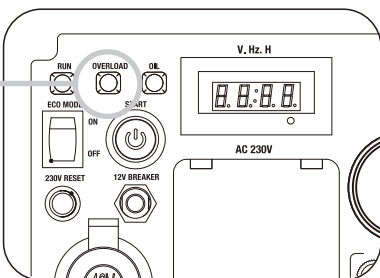

When the generating set has no output and the overload

indicator is on, please take the following steps:

1. Lower the total power of the connected electric devices to the rated output range of generating set.
2. Check the air intake and motor control parts for impurities. Handle immediately if necessary.
3. Press the reset button.

### Oil alarm lamp (yellow)

When the oil level drops below the lower limit, the oil protection system will stop the engine automatically. The oil alarm lamp will blink and the engine will not run until the oil has been filled to the proper level.

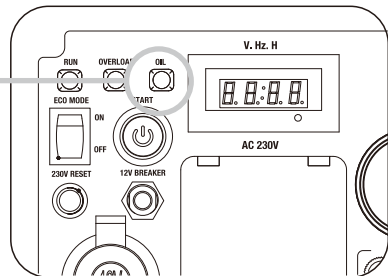

**Note:** If engine flames out or fails to start, turn the two-in-one switch to “RUN” position and then pull the recoil starter. If the oil alarming lamp lights up, it shows lack of oil. Please add appropriate oil and restart the engine.

## Energy-saving switch

When the energy saving switch is in the “ON” position, the engine will rotate its speed according to the connection loads. This enables low fuel consumption and low noise.

When the energy saving switch is in the “OFF” position, the engine will always run in a fixed rotation speed.

**Note:** Please set the energy saving switch to “OFF” position when connecting to an air compressor, sink pump etc., These types of equipment need a large starting current. If the power saving switch is not turned to the “OFF” position it will harm the inverter board.

shock by connecting it to the grounding wire. The generating set must be properly grounded before operation.

## Two-in-one switch (engine stop & fuel switch)

When the switch is in “OFF” position, it indicates that the engine stop switch and fuel switch are in off state.

When switch is in the “RUN” position, it indicates that the engine stop switch is off and the fuel switch is in the on position.

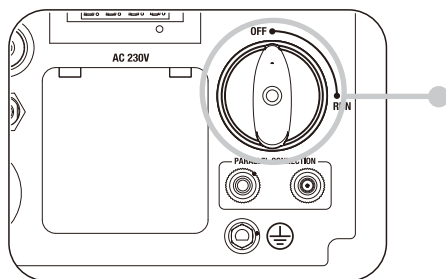
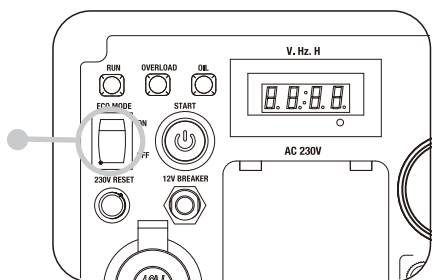

## Grounding terminal

The grounding terminal is designed to prevent electric

## Reset button

The reset button is used to restore output if an overload occurs. To restore output, reduce the loads and press the reset button.

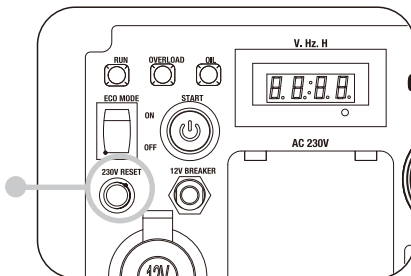
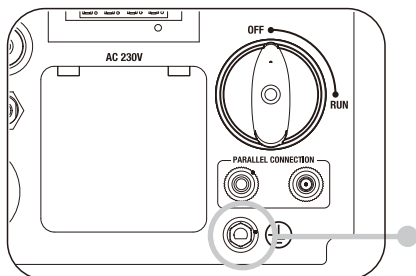

### Circuit breaker

The circuit breaker protects the generating set against electrical overloads.

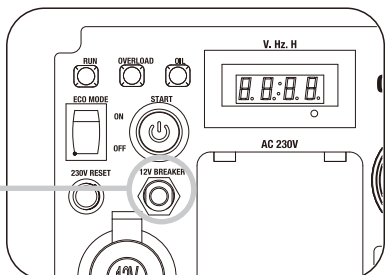

### Fuel tank cap

Remove the fuel tank cap by rotating it anticlockwise

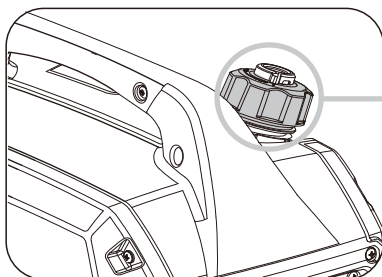

### Parallel kit terminal

It is used for parallel operation with another inverter (parallel kit sold separately).

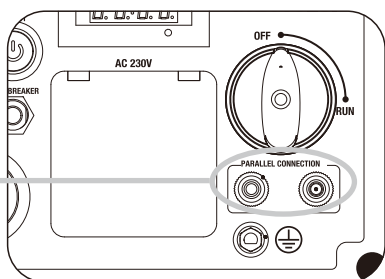

### Ventilation knob

The fuel tank cap is equipped with the ventilation knob to prevent leakage of fuel. Knob must be in the "ON" position when operating generating set. This enables the fuel to be injected into the carburetor and drive the engine. To avoid fuel leakage, turn it to "OFF" position when carrying or when not in use.

### Push-button start

You can start the generator by pressing a switch with your finger.

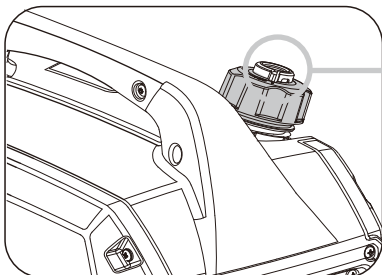
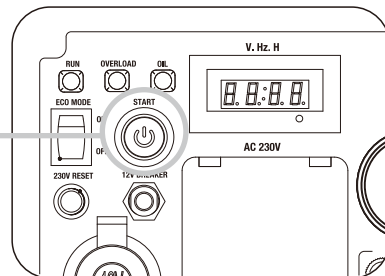

The ventilation knob must be in the "OFF" position when transporting. Fuel can be injected into the carburetor, this will cause the engine oil to thin and overflow.



## Operating

### Operating checklist

#### 1 Operating Location

Only use OUTSIDE and place the generating set in a well-ventilated area.

Only operate the generating set on a flat, level surface and in a clean, dry operating environment.

Allow two feet clearance on all side of the generating set while operating it outdoors.

Operate in specified area, if any problem on applicable occasion, please consult the authorized local authority. In some areas, generating set must be registered with the local utility. Generating set used to construction sites may be subject to additional rules and regulations.

**⚠ DANGER**

#### TOXIC FUMES

The exhaust of the generating set contains carbon monoxide, Using engine indoors **CAN KILL YOU!**

NEVER use inside any building or any kind of enclosure, **EVEN IF** doors and windows are open.

Place the generating set in a well-ventilated and clean area. Note the wind direction

and air current when place the engine.

#### High altitude

This generating set may require a high altitude carburetor kit to ensure correct operation at high altitudes. Consult the authorized local dealer for high altitude kit information if you always operate your engine at altitudes above 5, 000 feet (1,500 meters).

**⚠ CAUTION**

Even with carburetor modification, generating set horsepower will decrease about 3.5% for each 1,000 feet (300 meters) increase in altitude. The effect of altitude on horsepower will be greater than this if no carburetor modification is made.

**⚠ CAUTION**

Operation the engine at altitude below 5, 000 feet (1,500 meters) with modified carburetor may cause the generating set to overheat and result in serious engine damage. Please restore factory specifications of the carburetor at the dealer when using the engine in a low altitude area.

#### 2 Operating Condition

Check for loose or damaged parts, signs of oil or fuel leaks, and any other condition that may affect proper operation.

Repair or replace all damaged or defective parts immediately.

**⚠ WARNING**

Failing to correct problem(s) before operation could result in property damage, serious injury or DEATH.

Remove any excessive dirt or debris, especially around the muffler and recoil starter.

DO NOT move or tip the generating set during operation.

Use generating set only for intended uses. If you have questions about intended use, ask your local dealer.

**3 Engine oil check**

Place the engine on a level surface with engine stopped. Check the engine oil level.

Remove the oil maintenance cover.

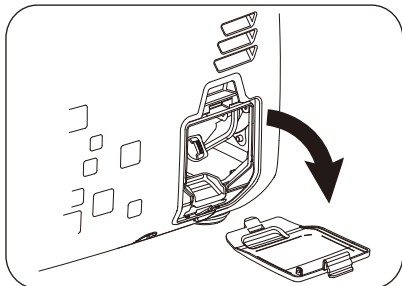

Remove the dipstick and wipe it clean.

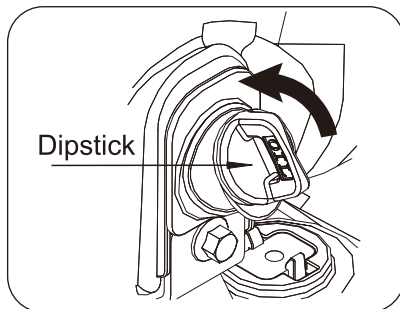

Reinstall dipstick into sump hole; rest on oil fill neck. DO NOT thread cap into sump.

Remove the dipstick again and check oil level. Level should be between the upper and lower limit.

Fill to the upper limit of the dipstick with the recommended oil if the oil level is too low.

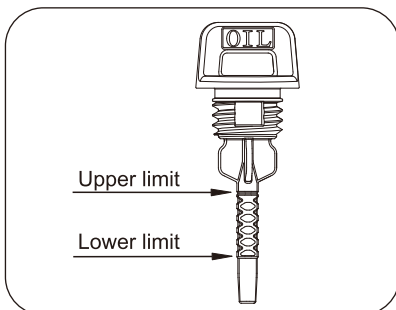
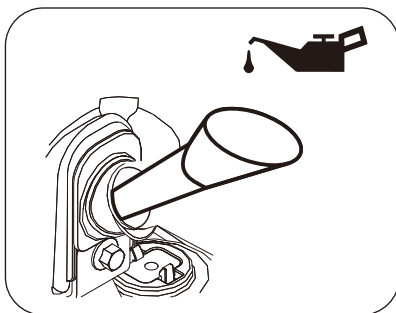

Reinstall and fully tighten the dipstick.

Refer to **add oil** instruction in **MAINTENANCE** section for more information.

**Oil capacity(rated):**

**See Parameters**

### **⚠ WARNING**

Oil is a major factor affecting performance and service life. Use 4-stroke automotive detergent oil recommended in the **MAINTENANCE** section of this manual.

### **⚠ CAUTION**

Operate generating set only on leveled surfaces. The engine is equipped with a low oil sensor (applicable types) that will automatic stop the engine when the oil level falls below the safe limit. To avoid the inconvenient of an unexpected shutdown. Fill to the upper limit and check the oil level regularly.

### **⚠ WARNING**

This engine is not filled with oil before send out to the factory. Any attempt to crank or start the engine before it has been properly filled with the recommended type and amount of oil may result in engine damage and void your warranty.

## **4** **Generating set fuel check**

With the engine stopped, check the fuel level. Refill the fuel tank if necessary.

Use clean, fresh, regular unleaded gasoline.

DO NOT mix oil with gasoline.

Always wipe up any spilled fuel.

### **⚠ CAUTION**

Pressure can build up in the fuel tank. Allow the generating set to cool for at least two minutes before removing fuel cap.

Loosen the fuel cap slowly to relieve any pressure in the tank.

Be sure not to fill above the upper limit mark. Always allow room for fuel expansion.

**Fuel capacity (rated):**

**See parameters.**

**⚠ DANGER****FIRE OR EXPLOSION**

Gasoline is highly flammable and extremely explosive.

Keep flammable items away while handling gasoline.

Fill fuel tank outdoors and in a well-ventilated area with the generating set stopped.

Always wipe off spilled fuel and wait until the fuel has dried before starting the generating set.

DO NOT operate the generating set with known leaks in the fuel system. Regularly check if there is any leak on fuel system.

Use proper fuel storage and handling procedures. DO NOT store fuel or other flammable materials nearby.

Keep fire extinguisher handy and be prepared if a fire starts.

**⚠ DANGER**

Do not fill the fuel tank above the upper limit. Over fill will result in engine die or damage the carbon canister (if equipped) and void your warranty.

**⚠ CAUTION**

To minimize gum deposits in your fuel system and to insure easy starting, do not use gasoline left over from the previous season.

NEVER use engine or carburetor cleaner products in the fuel tank or permanent damage may occur.

It is important to prevent gum deposits from forming in essential fuel system parts,

Such as the carburetor, fuel filter, fuel hose or tank during storage. Also, experience indicates that alcohol-blended fuels (called gasohol, ethanol or methanol) can attract moisture, which leads to separation and formation of acids during storage.

Acidic fuel can damage the fuel system of the generating set while in storage. Be sure to review the instructions given in "Storage" section.

Gasoline/Alcohol blends: up to 10% alcohol, 90% unleaded gasoline by volume is approved as a fuel. Other gasoline/alcohol blends are not approved.

Effects of old, stale or contaminated fuel are not warrantable.

**⚠ CAUTION**

Allow the generating set to cool for at least two minutes before removing fuel cap when adding fuel.

Loosen the fuel cap slowly to relieve any pressure in the tank.

**5 Internal battery grounding**  
(Applicable types)

Remove the appearance cover plate. Use the nut of M6 to connect the battery grounding wire with cylinder head cover to make the ground connection of internal battery.

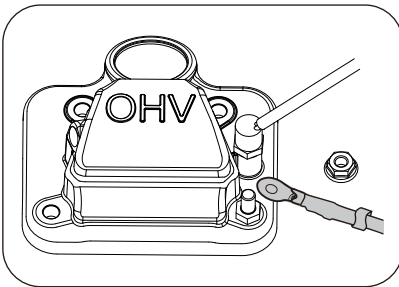

**6 Electrical devices**

Disconnect all electrical devices from the generating set and switch off the AC circuit breaker before start the engine.

The generating set may be hard to start with electrical devices connected.

The power of connected electrical devices cannot limit

the generating set max power, specific power see parameter sheet for reference.

**7 Generating set grounding**

The generating set must be properly connected to an appropriate ground. It helps prevent electrical shock if a ground fault condition exists in the generating set or in connected electrical devices, especially when the unit is equipped with a wheel kit.

Proper grounding also helps dissipate static electricity, which often builds up in ungrounded devices.



**⚠ DANGER**

**Electrical Shock**

Failure to properly ground the generating set can result in electric shock.

A ground terminal has been provided on the generating set.

For remote grounding, connect of a length of heavy gauge (4mm<sup>2</sup>) copper wire between the generating set ground terminal and a copper rod driven into the ground.

Local electrical codes may also require proper grounding of the unit. We strongly recommend that you consult with a qualified electrician for grounding requirements in your area.

## Starting the Generator Set

**1**

Perform operating checklist (see page 13) and remove all loads.

**2**

Turn the ventilation knob to “ON” position when engine is running to make sure the fuel flowing.

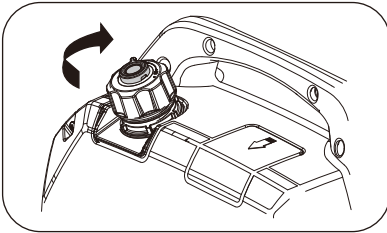
**3**

Turn the two-in-one switch to the “RUN” position.

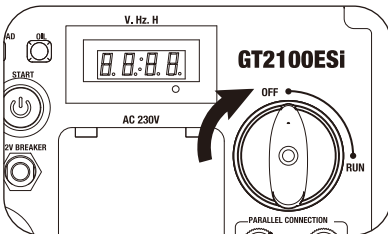
**4**

Turn the energy saving switch to the “ON” position. (Note: Please set the energy saving switch to the “OFF” position when powering high current drawing devices.)

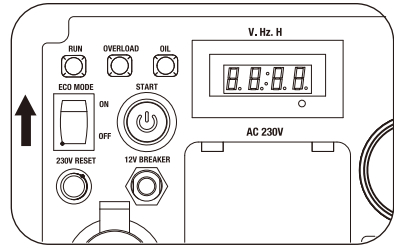

**5**

## Manual Starting Hand recoil starting

### ⚠ CAUTION

Check starter cord conditions before operating. Have it replaced immediately by local authorized dealer if cord is frayed.

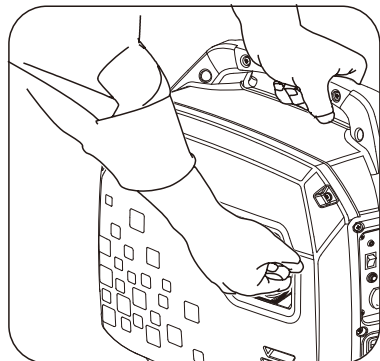
When starting engine, grasp the recoil starter handle and pull slowly until resistance is felt. Then pull rapidly to avoid kickback. When pulling the recoil starter, firmly grasp the carrying handle to avoid tumble of generating set.



**⚠ WARNING**
**KICKBACK**

Rapid retraction of the starter cord will pull hand and arm towards the engine faster than you can let go.

Unintentional startup can result in entanglement, traumatic amputation or laceration. Broken bones, fractures, bruises or sprains could result.

If the starter cannot drive the engine to rotate, turn off the starter immediately. Do not attempt to start the engine again before finding the causes of the fault. Prohibit the unauthorized change of other battery for re-start.

**⚠ CAUTION**

If the engine fails to start after attempt for 3 times or flames out after starting, inspect and ensure that the generating set is placed in horizontal surface and enough engine oil is injected.

If engine is equipped with an engine oil alarm, it is possible to prevent engine start when the engine oil in the crankcase is lower than the minimum level.

During running-in, routinely inspect the engine oil. See maintenance section for recommended maintenance period.

**⚠ WARNING**

The engine starts time cannot exceed 15 minutes. If the engine fails to start, allow the starting motor to cool for one minute before restart. Failure to operate according to this rule will damage the starting motor.

**Electric Starting**

Press the engine switch and release it after the engine starts.

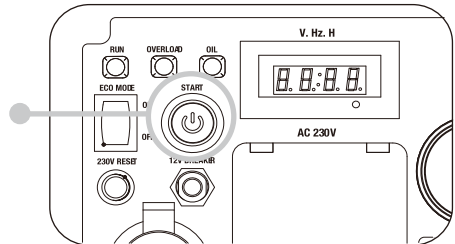

If the starter cannot crank the engine, please release the switch button. Do not attempt to start the engine again before figuring out the cause(s).

Modification or using other battery to start the engine is not allowed due to warranty conditions..

If the engine speed is raised to the speed over the starter but does not keep running (fails to start), then the engine must be completely stopped before starting again. If when the flywheel starts to rotate automatically, the starter is still engaged, then there may be a conflict between the flywheel external gear and the starter pinions, and this may cause damage to the starter.

**⚠ WARNING**

When the starting battery of the generator set is low in voltage and pull starting the generator does not work, please make sure the fuel tap is in the on position. Please try and operate the choke lever according to the below diagram. This will add choke to the engine to help the generator engine to start when the battery is low in volts and not being able to move the choke automatically.

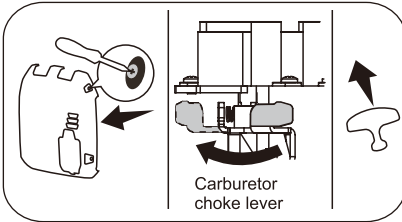

**6**

After all above operations, the engine can be normally loaded.

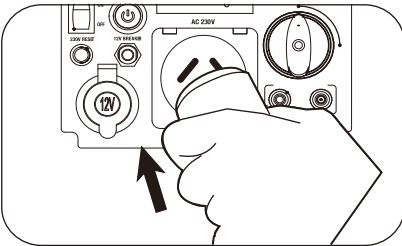

**⚠ WARNING**

It is prohibited to start or stop the generator when using electrical equipment or loading the generator set.

**Remote Control Use**  
(For remote control function)

**Safety Regulations for Operating**

**⚠ WARNING**

- Read carefully and understand this manual before using the generator and the wireless remote control or it may cause equipment damage.
- To avoid the battery running out, turn off the remote control switch if idling the generator for a long time
- Keep out of the reach of children

**NOTE:**

- Do not disassemble remote control.
- Avoid heat.
- Avoid dropping.
- Do not put into water.

**Technical Specifications**

Model No.	KE888		
Working voltage	DC12 V	Working current	16-7 mA
Working band	315 MHz	Modulation system	ASK (FM)
Emissive power	10 mW	Transmitting distance	30-50m (Open space)
Encoding type	Tri-code	Working temperature	-10°C - 50°C
Dimensions	Wireless remote controller	58x30x11.8mm	
	Remote receiver	83x65x26mm	

**Remote receiver**

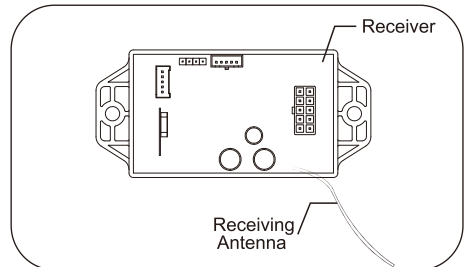



## Wireless remote control

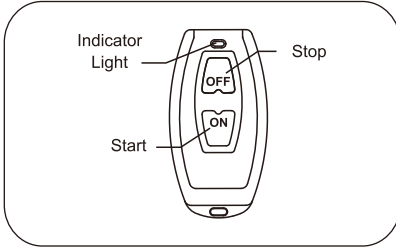

### Operating

1. Turn on the remote control switch.
2. Press the START button and hold for more than 0.3s for startup.

### NOTE:

- Sometimes the generator can take a few attempts to start in cold weather. If machine does not start in the first 10 seconds, wait for 30 seconds before attempting again.
- If the motor turns a little then stops when you press the Start key, it may indicate a low battery. Charge the battery before operation or start by recoil start.

### Stopping

1. Press the STOP key repeatedly for 2-3 seconds to stop the generator from running.

### NOTE:

- Replace battery when the control distance is inadequate, and/or when the indicator light on remote control is not functioning. See maintenance section for more info.

## Connecting to Electrical Devices

### Note:

1. Inspect power cord for damage before using. There is a hazard of electrical shock from crushing, cutting or heat damage.
2. Make sure that the generating set has been properly grounded. If the electric devices require grounding, the generating set must ground.
3. Allow the engine to stabilize and warm up for a few minutes after starting.
4. Make sure that the electric devices are in "OFF" position.
5. Connect and start the electric devices.
6. Turn off all electric devices and disconnect them from the generating set.
7. If the generating set is supplying several loads, start the smallest one first and the largest one last.

### **CAUTION**

If connected devices overheat, turn them off and disconnect them from generating set.

**⚠ DANGER**
**ELECTRICAL SHOCK**

To reduce the risk of electrical shock, **DO NOT** use electrical cords that are worn, frayed, bare or otherwise damaged.

**DO NOT** touch bare wires or receptacles.

**DO NOT** handle generating set or electrical cords while standing in water, while barefoot, or while hands or feet are wet.

**Loading Capacity**
**⚠ WARNING**
**DO NOT overload the generating set.**

Exceeding the generating set's capacity can damage the generating set and/or electric devices connected.

You must make sure your generating set can supply enough rated (running) and (starting) watts for the electrical devices at the same time. Follow these simple steps to calculate the running and starting watts necessary for your purposes.

a. Count the electrical devices you will power at the same time.

b. The amount of power you need to run with the devices is the total rated (running) watts of these items.

c. Starting power is the power needed shortly when electric devices start. Since not all devices start at the same time, starting power can be estimated by the maximum power of all devices plus the total power counted in step b.

**⚠ WARNING**

It is necessary to equip with circuit protector or switch to isolate the generating set from the electric utility when the generating set is mainly used for backup. Failure to isolate the generating set from the power utility may result in injury or death to electric utility workers and damage to the generating set due to back feed of electrical energy.

**Wattage Reference Chart**

Electric equipment		Rated power(W)	Starting power(W)
Appliances	Tablet computer 27"	80	100
	Energy saving lamp	5-50	5-50
	Electric cooker	1000	1000
	Computer	250	250
	Electric fan	50	100
	Washing machine	250	500
	Refrigerator	50	300
	Air-conditioner	1600	3200
Electric tooling	Electric hammer	1000	1500
	Impact hammer	3000	6000
	Water pump	2200	5000
	Electric welding machine	5000	7500
	Air compressor	5000	10000

## Stopping the Generator Set

**1**

Remove the connectors of all electric equipment from the generating set panel.

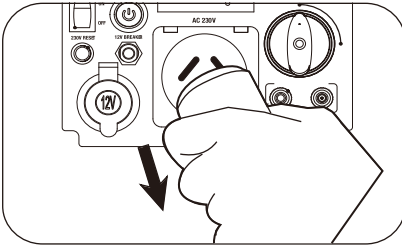

### **⚠ WARNING**

NEVER stop the engine with electrical devices connected and running.

**2**

Turn the energy saving switch to the “ON” position.

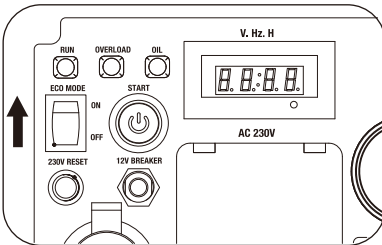

**3**

Allow the generating set run at no load for a few minutes to stabilize internal temperatures of the engine and generating set.

**4**

Turn the two-in-one switch to “OFF” position.

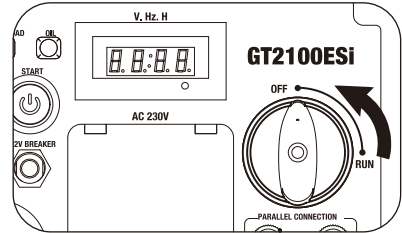

## Parallel Operation

(If applicable)

Make sure that the generating set is in a good running state before connecting it to other generating sets. The total power of electric devices should not exceed rated power of generating set.

When electric motor starts, the overload indicator (red) will light up and normally it will stop within 4 seconds. If the red light stays on, consult your local dealer.

During parallel operation, energy-saving switches of generating sets should be in the same position.

**1**

Connect one generating set to other generating set(s) in parallel. Use the parallel kit to make the parallel connection (the parallel kit needs to be purchased separately).

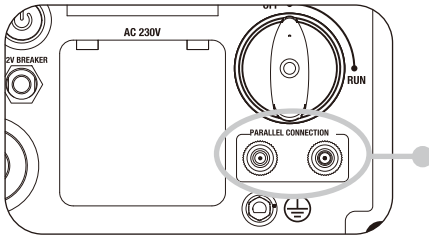
**2**

Start the engine in proper order and make sure that the running indicator (green) is normal.

**3**

Connect the plug of electric devices to the AC receptacle of parallel kit.

**4**

Run the electric devices.

**⚠ CAUTION**

Constant overloading of the generator set will compromise the inverter and can overload the components internally. This type of overloading will shorten the life of the generator.

**⚠ CAUTION**

The total power of electric devices cannot exceed the rated power of generating set. The manufacturers of electric devices or tools always list the rated power of similar models or serial number.

**Maintenance**

It is the operator's responsibility to complete all scheduled maintenance in a timely manner. Correct any issue before operating the generating set. Always follow the inspection and maintenance recommendations and schedules in this manual.

**⚠ WARNING**

Improper maintenance or failure to correct a problem before operation can cause a malfunction and result in property damage, serious injury or DEATH.

Improper maintenance will void your warranty.

**⚠ DANGER**

Accidental starts can cause Severe injury or death. Remove and ground spark plug wire before performing any service.

## Maintenance Schedule

Stop the generating set before serving, disconnect all electric devices and battery (if equipped), and cool down the generating set completely.

Serve the generating set in a clean, dry and flat area, so that no accident would happen during the serving. Please make the wheel in brake state to stop accidental movement of generating set.

Follow the service intervals indicated in the chart below. Service your generating set more frequently when operating in adverse conditions.

Contact your local authorized service dealer for your generating set or engine maintenance needs.

		Each time before use	The first month or 10 hours <small>note2</small>	Every three months or 50 hours <small>note2</small>	Every six months or 100 hours <small>note2</small>	Every year or 300 hours <small>note2</small>
Engine oil	Inspection	√				
	Replacement		√	√	√	
Air filter	Inspection	√				
	Cleaning		√	√ <sup>note3</sup>	√	√
Spark plug	Inspection and adjustment				√	
	Replacement			√		√
Spark Extinguisher <sup>note1</sup>	Cleaning		√	√	√	√
Idle speed	Inspection and adjustment					√ <sup>note4</sup>
Valve clearance	Inspection and adjustment					√ <sup>note4</sup>
Carbon canister <sup>note1</sup>	Inspection	Every two years <sup>note4</sup>				
Low permeability oil tube <sup>note1</sup>	Inspection	Every two years <sup>note4</sup>				
Oil tube	Inspection	Every two years <sup>note4</sup>				

### NOTE :

Note1: Applicable types (if available).

Note2: Before each season and after then (whichever comes first).

Note3: Service more frequently under severe, dusty, dirty conditions.

Note4: To be performed by knowledgeable, experienced owners or the authorized dealer.

## Remote Control Battery Replacement

When the control distance is inadequate, and/or when the indicator light on remote control is not functioning you will need to replace battery as follows:

1. Unscrew the three screws on the back of the control with a phillips screwdriver.
2. Replace the battery. (DC6V)
3. Re-assemble.

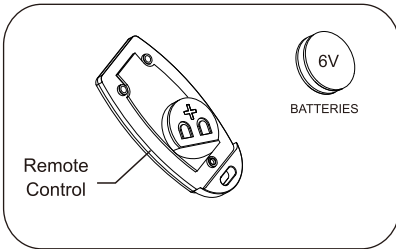
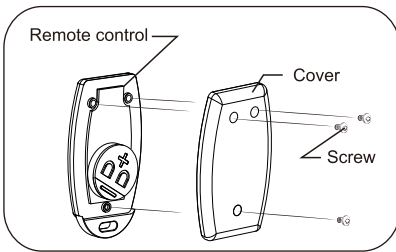

### NOTE:

- Do not put upside down (the end with spring has to connect to the cathode. The wrong direction may damage the control and the battery.
- Do not replace the battery with wet hands. Water may cause rust and damage the control.
- Do not touch or move any component, it may cause control to not work properly.
- Do not bend the electrode.
- Avoid dust or oil coming into contact with remote control.

## Storing the Remote Control

Ensure storage area is dry and clean before storing away.

Take battery out of controller before storing.

## Generating Set Maintenance

Use a damp cloth to clean exterior surfaces of the generating set. Use a soft brush to clean the dirt and oil.

Use an air compressor (25 PSI) to clear dirt and debris from the generating set.

Inspect all air vents and cooling slots to ensure that they are clean and unobstructed.

### **⚠ WARNING**

DO NOT use water to clean the generating set. Water can enter the generating set through the cooling slots and damage the generating set windings.

### **⚠ WARNING**

DO NOT modify the generating set in any way. DO NOT tamper with modified the speed regulator. Generating set supplies correct rated frequency and voltage when running at factory set.

Tampering with modify the factory set governor will void your warranty.

## Engine Maintenance

### Engine oil

Only use four-stroke engine oil of SJ, SL or equivalent level which are in accordance with or higher than API standard.

Check the API label on oil bottle or other container, and make sure the "SJ, SL" or equivalent level letter is in the label.

SAE 10W-30 is recommended for general, all-temperature use. Other viscosities shown in the chart may be used when the average temperature in your area is within the indicated range.

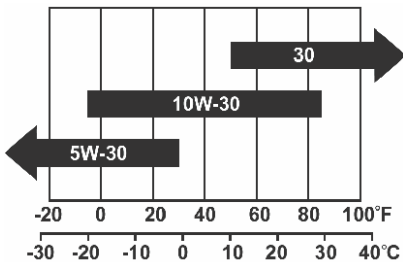

Ambient temperature

**Oil capacity (rated):**

**See parameters**

### Add oil

- Place the engine on a level Surface.
- Remove the dipstick and wipe it clean.

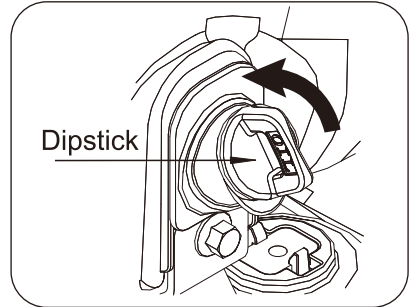

- Add recommended oil to the upper limit.

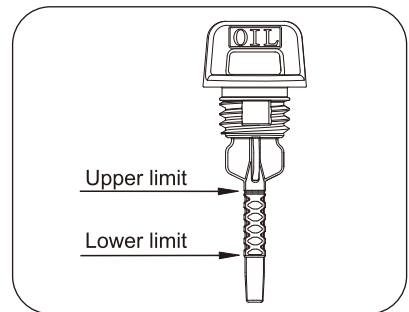
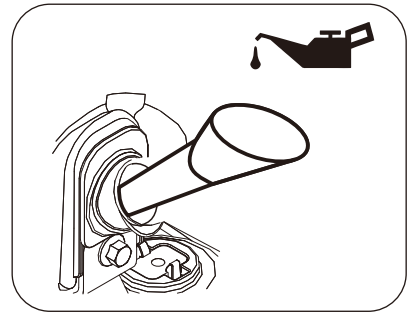

- Fully tighten the dipstick.

### **CAUTION**

#### Oil level check

Reinstall dipstick into hole; rest on oil fill neck. **DO NOT** thread cap into hole.

e. Properly dispose of any used oil at an approved waste management facility.

**Change oil**

**CAUTION**

Change oil when the engine is warm from operation.

a. Place the machine on a level surface which is 300mm higher than the ground.

b. Remove the oil maintenance cover.

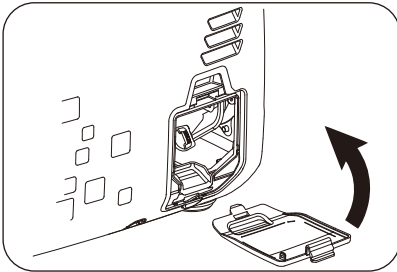

c. Place the waste oil box on the ground.

d. Remove the oil dipstick, and tilt the machine to pour the oil.

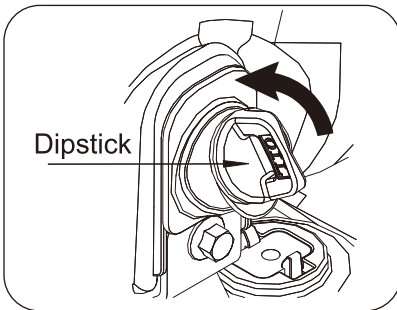

e. Add recommended oil to the upper limit.

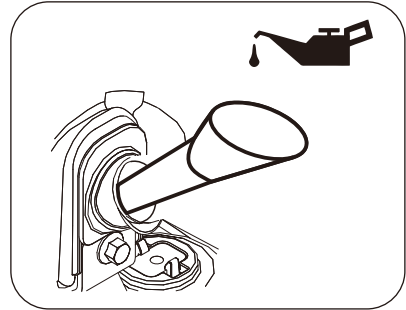

f. Fully tighten the dipstick.

g. Properly dispose of any used oil at an approved waste management facility.

h. Reinstall the oil maintenance cover.

**WARNING**

The engine is not filled with oil at the factory. Any operation before it has been properly filled with the recommended type and amount of oil may result in engine damage and void your warranty.

**Air filter**

a. Remove the appearance cover.

b. Loosen the filter fix clamp and remove the cover of the air filter.

c. Remove the foam filter element.

d. Wash in liquid detergent and warm water.

e. Squeeze thoroughly dry in a clean cloth.



- f. Saturate in clean engine oil.
- g. Squeeze in a clean absorbent cloth to remove all excess oil.
- h. Assemble the filter element onto the filter unit
- i. Assemble the filter fix clamp.
- j. Reinstall the appearance cover.

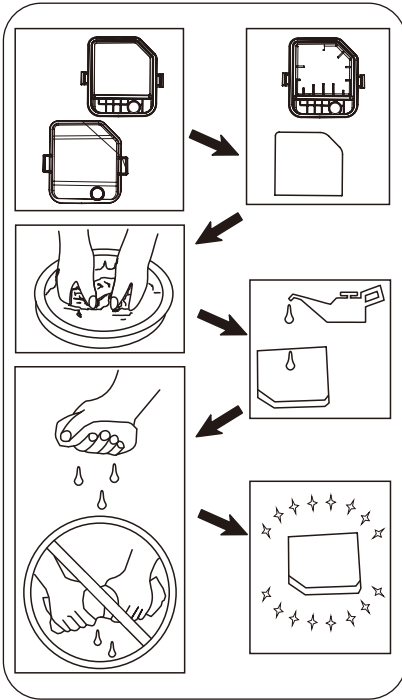

**⚠ WARNING**

DO NOT run the engine without the air filter, or serious danger can result.

**Spark plug**

- a. Clean any dirt from the spark plug cap and spark plug base.
- b. Remove the spark plug cap.
- c. Using socket wrench to loose and remove the spark plug.
- d. Inspect the spark plug and spark plug washer, if it was broken or worn, replace with a new one. Clean the spark plug with wire brush if reuse it.
- e. Check spark plug gap. Carefully bend side electrode to adjust the gap if necessary.

**Spark plug gap:**

**0.6mm-0.8mm**

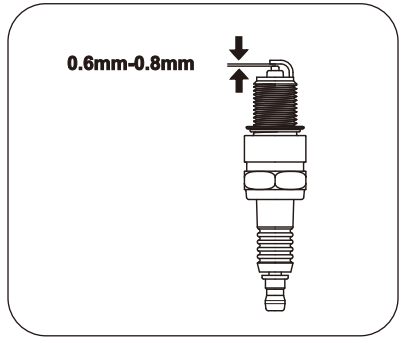

- f. Carefully thread the plug into the engine **by hand**.
- g. After the spark plug is seated, use spark plug wrench to tighten the plug.

**Spark Plug Tighten Torque:**

**15-20 N.m**

- h. Attach the spark cap to the plug and connect the spark plug wire to the plug.

**⚠ WARNING**

Only use recommended spark plug or equivalent. DO NOT use spark plugs that have improper heat range.

**Spark Arrester**

(Applicable types)

- a. Allow the generating set to cool completely before servicing the spark arrester.
- b. Remove the muffler blind window first.
- c. Remove the spark arrester screen.
- d. Carefully remove the carbon deposits from the spark arrester screen with a wire brush.
- e. Replace the spark arrester if it is damaged.
- f. Reinstall the spark arrester in the muffler and reinstall the muffler blind window.

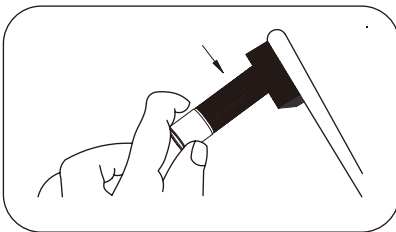

Clean carbon deposit



## Troubleshooting

Failure	Trouble	Solution
Generating set fails to start	Two-in-one switch is in “OFF” position.	Turn two-in-one switch to the “RUN” position.
	Lack of fuel.	Fill fuel tank per instructions in this manual.
	Lack of engine oil.	Check oil level. This engine is equipped with a low oil sensor. The engine cannot be started unless the oil level is above the prescribed lower limit.
	No ignition.	Remove the spark plug cap. Clean any dirt around the plug base, and then remove the spark plug. Install the spark plug and plug cap. Turn the two-in-one switch to “RUN” position. Grounding the electrode to any engine ground, pull the recoil starter to see if sparks jump across the gap. If there is no spark, replace the plug.  Reinstall the plug and start engine according to instructions in this manual. Consult Customer Service if necessary.
	Spark plug is splashed by fuel	Remove the spark plug and wipe the fuel.
Generating set has no output	The generating set flames out after running for a certain time.	Turn the ventilation knob on the fuel tank cap to “ON” position; Check the fuel and oil level. Add them if necessary.
	Breaker trip	Reset circuit breakers and check electrical equipment.
Generating set has no output	Inadequate cord sets or extension cords.	Check cord sets or extension cords capabilities in section controls; cable size in this manual.  Consult Customer Service if necessary.

## Storage and Transportation

### Storage

The generating set should be started at least once every 2 weeks and allowed to run for at least 20 minutes. Follow the instructions below for longer term storage if the generating set will be out of service for 2 months or more.

⚠ DANGER

**Fire or explosion**

Gasoline is highly flammable and extremely explosive.

Empty the fuel tank and shut off fuel valve before storing or transporting this generating set.

1. Allow the generating set to cool completely before storage.
2. Clean the generating set according to instructions in Maintenance section.
3. Drain all fuel completely from the fuel tank, fuel hose and carburetor to prevent gum from forming from the stale fuel.
4. Close the fuel switch to cut down fuel supply.
5. Remove the appearance cover plate. Unscrew the oil dipstick and slightly tilt the whole set to pour out the oil.
6. Remove the spark plug and pour about 15 ml of oil into the cylinder. Pull the recoil starter

slightly to distribute the oil and lubricate the cylinder. And then attach the spark plug.

7. Store the unit in a clean, dry area out of direct sunlight.

### Transportation

To prevent fuel spillage when transporting or during temporary storage, the generating set should be secured upright in its normal operating position, with the engine switch OFF. The two-in-one switch should be turned OFF.

⚠ WARNING

**When transporting:**

Do not overfill the tank. Do not operate the generating set while it is on vehicle. Take the generating set off the vehicle and use it in a well-ventilated place. Avoid a place exposed to direct sunlight when putting the generating set on a vehicle. If the generating set is left in an enclosed vehicle for many hours, high temperature inside the vehicle could cause fuel to vaporize resulting in a possible explosion. Do not drive on a rough road for an extended period with the generating set on board. If you must transport the generating set on a rough road, drain the fuel from the generating set beforehand.

## Remote Control Storage

Ensure storage area is dry and clean before storing away.

Take battery out of controller before storing.

## Specifications

### Specification Parameter Table

Feature		Model	GT2100ESi
Engine parameter	Engine model		148ESi
	Style		OHV
	Displacement (cm <sup>3</sup> )		79
	Ignition system		CDI
	Start style		electric starting
	Oil capacity(L)		0.5
Series parameter	Frequency(Hz)		50
	Voltage(V)		230
	Rated power(kW)		1.7
	Maximum power(kW)		2.0
	Power factor		1
	Insulation rate		F
	Fuel capacity(L)		4
	Max. site ambient temperature(°C)		40
	Max. site altitude of installation(m)		1500
	Measured sound pressure level(dB(A))		51dB
Net weight(kg)		19.7	

**Note:** The generating set with different specification and configurations may have different parameters and may change at any time without notice.

## Wiring Diagram

### GT2100ESi

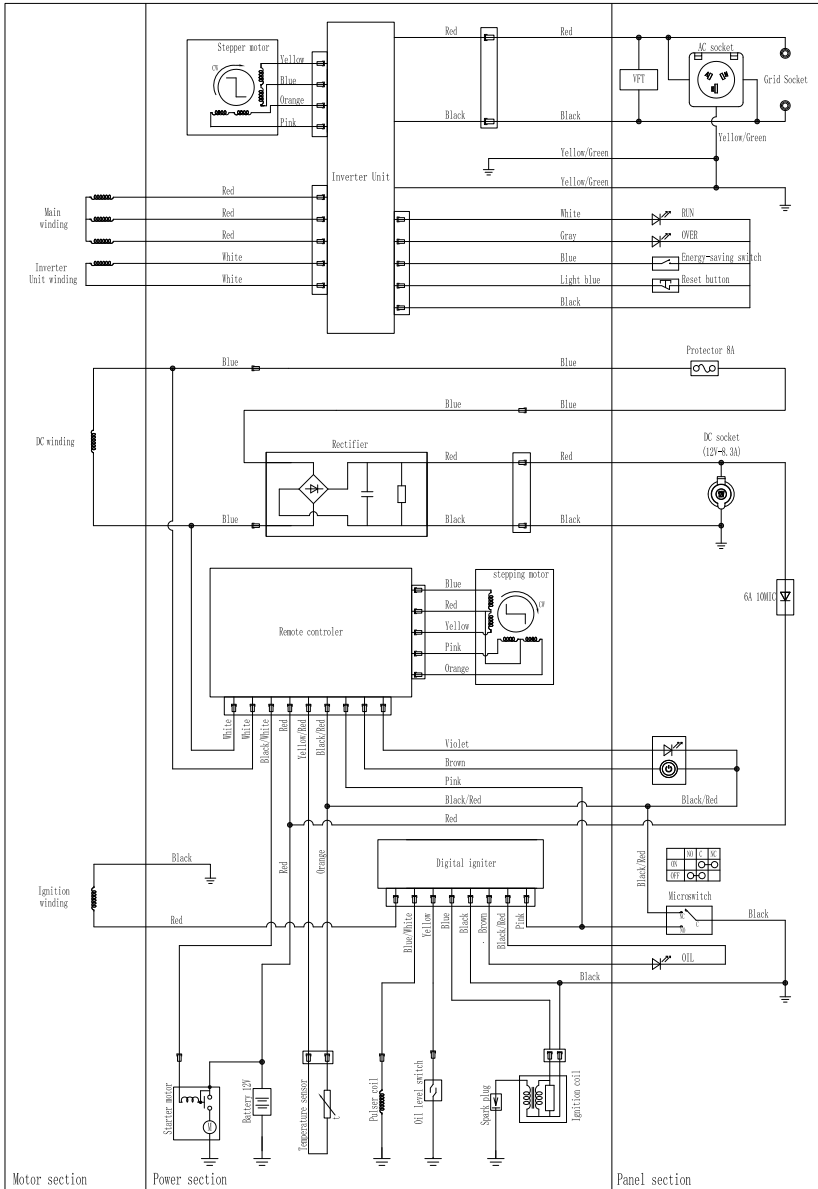

NOTE: Because of the difference of generator, the wiring diagram is only for reference.

## Warranty

As part of an on-going commitment to excellence in product support, Euroquip offers a comprehensive product warranty program.

In order to qualify for full warranty support, your product must be registered. Product not registered with Euroquip is supported by a base 12 month warranty only. Spare parts and technical support will not be available for an unregistered product outside of this base warranty period. If a Euroquip dealer has not already registered your product, please register it online or download a physical registration form at [www.euroquip.co.nz](http://www.euroquip.co.nz).

### Registered warranty period for the GT2100ESI

**Commercial Use: 24 Months**

**Domestic Use: 24 Months**

Warranty covers failure caused by manufacturing and material defects in the product, during the warranty period specified. The warranty period begins when the product is purchased by the end user. Warranty is not transferrable and is only claimable by the original purchaser.

Warranty does not cover parts that are subject to wear and tear from usage.

Warranty covers failure of a product caused by defective materials and/or manufacturing for the period given and the usage specified by Euroquip. The warranty period begins when the product is purchased by the end user. Warranty is not transferrable and is only claimable by the original purchaser.

Warranty also does not cover failure caused by the untimely replacement or service of the above wearing parts. Evidence must be provided that the product has been maintained and serviced suitably for a claim to be considered under warranty.

Failure caused by incorrect operation of the product, lack of proper care and maintenance of the

product, external damage, external circumstances such as contaminated fuel or poor water supply, modifications to the product, attempted repair/service by a party other than an Approved Service Agent, is not covered under warranty.

Warranty does not cover pre delivery service and adjustment, or failure that may occur as a result of lack of/ incorrect pre delivery service and adjustment.

Warranty does not cover any incidental, indirect or consequential loss, damage or expense that may result from any defect, failure or malfunction of a product.

Should any issue be found to be a combination of a warranty failure and a non-warranty issue, the repair cost component to rectify and repair the non-warranty failure is the customers' full responsibility.

The decision that an issue with a product qualifies as a warranty claim is made at the sole jurisdiction of Euroquip.

No costs incurred will be considered under warranty if repairs are carried out by a party other than a Euroquip Approved Service Agent, unless with prior consent in writing from Euroquip.

It is the responsibility of the purchaser to deliver a product under warranty to the nearest relevant service agent or product reseller. Warranty does not cover call outs, mileage and freight costs.

If a product is repaired under warranty, parts and labour required for the repair will be supplied at no charge. Warranty assessment and repair will be scheduled and executed according to the normal work flow at the service location and depending on the availability of suitable replacement parts.

This warranty policy is an additional benefit and does not affect the legal rights of any end user, reseller or service agent.



Congratulations on your new GT POWER product. We are proud to have you as our customer and will strive to provide you with the best service and reliability in the industry. This product is backed by our extensive warranty and service network. To locate your nearest distributor or service agency visit [www.euroquip.co.nz](http://www.euroquip.co.nz) or email us at [customerservice@euroquip.co.nz](mailto:customerservice@euroquip.co.nz).